



AH114 / ECG009

1/4 Watt, High Linearity InGaP HBT Amplifier

The Communications Edge™

Product Information

Product Features

- 60 – 2500 MHz
- +24 dBm P1dB
- +41 dBm Output IP3
- 19 dB Gain @ 900 MHz
- 14.5 dB Gain @ 1900 MHz
- +5V Single Positive Supply
- Available in a lead-free / green SOT-89 Package Style

Applications

- Final stage amplifiers for Repeaters
- Mobile Infrastructure
- DBS / WLL / WLAN / WiBro
- Defense / Homeland Security

Product Description

The AH114 / ECG009 is a high dynamic range driver amplifier in a low-cost surface mount package. The InGaP/GaAs HBT is able to achieve high performance across a broad range with +41 dBm OIP3 and +24 dBm of compressed 1dB power. It is housed in a lead-free/green/RoHS-compliant SOT-89 SMT package. All devices are 100% RF and DC tested.

The AH114 / ECG009 is targeted for use as a driver amplifier in wireless infrastructure where high linearity and medium power is required. An internal active bias allows the AH114 / ECG009 to maintain high linearity over temperature and operate directly off a single +5V supply. This combination makes the device an excellent candidate for transceiver line cards in current and next generation multi-carrier 3G base stations.

Functional Diagram

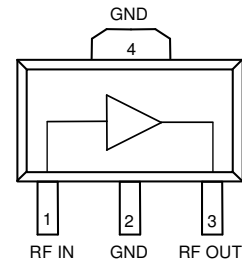

Function	Pin No.
Input / Base	1
Output / Collector	3
Ground	2, 4

Specifications ⁽¹⁾

Parameters	Units	Min	Typ	Max
Operational Bandwidth	MHz	60		2500
Test Frequency	MHz		1900	
Gain	dB	13.5	14.5	
Input Return Loss	dB		10	
Output Return Loss	dB		14	
Output P1dB	dBm		+23	
Output IP3 ⁽²⁾	dBm	+39.5	+41	
IS-95A Channel Power @ -45 dBc ACPR	dBm		+17	
Noise Figure	dB		5.0	
Test Frequency	MHz		2140	
Gain	dB		14	
Output P1dB	dBm		+23	
Output IP3 ⁽²⁾	dBm		+40	
Operating Current Range	mA	130	150	170
Device Voltage	V		+5	

1. Test conditions unless otherwise noted: 25°C, Vsupply = +5 V, in tuned application circuit.
 2. 3OIP measured with two tones at an output power of +11 dBm/tone separated by 1 MHz. The suppression on the largest IM3 product is used to calculate the 3OIP using a 2:1 rule.

Typical Performance ⁽¹⁾

Parameters	Units	Typical		
Frequency	MHz	900	1900	2140
S21 - Gain	dB	19	14.5	14
S11 - Input R.L.	dB	-14	-10	-25
S22 - Output R.L.	dB	-10	-14	-20
Output P1dB	dBm	+24	+23	+23
Output IP3	dBm	+40	+41	+40
Noise Figure	dB	5.0	5.0	6.0
Supply Bias		+5 V @ 150 mA		

Absolute Maximum Rating

Parameter	Rating
Operating Case Temperature	-40 to +85 °C
Storage Temperature	-65 to +150 °C
RF Input Power (continuous)	+15 dBm
Device Voltage	+6 V
Device Current	220 mA
Junction Temperature	+250 °C

Operation of this device above any of these parameters may cause permanent damage.

Ordering Information

Part No.	Description
AH114-89	1/4 Watt, High Linearity InGaP HBT Amplifier (lead-tin SOT-89 Pkg)
ECG009B	1/4 Watt, High Linearity InGaP HBT Amplifier (lead-tin SOT-89 Pkg)
AH114-89G	1/4 Watt, High Linearity InGaP HBT Amplifier (lead-free/green/RoHS-compliant SOT-89 Pkg)
AH114-89PCB900	900 MHz Evaluation Board
AH114-89PCB1900	1900 MHz Evaluation Board
AH114-89PCB2140	2140 MHz Evaluation Board

Specifications and information are subject to change without notice



Typical Device Data

S-Parameters (Vcc = +5 V, Icc = 150 mA, T = 25°C, unmatched 50 ohm system)

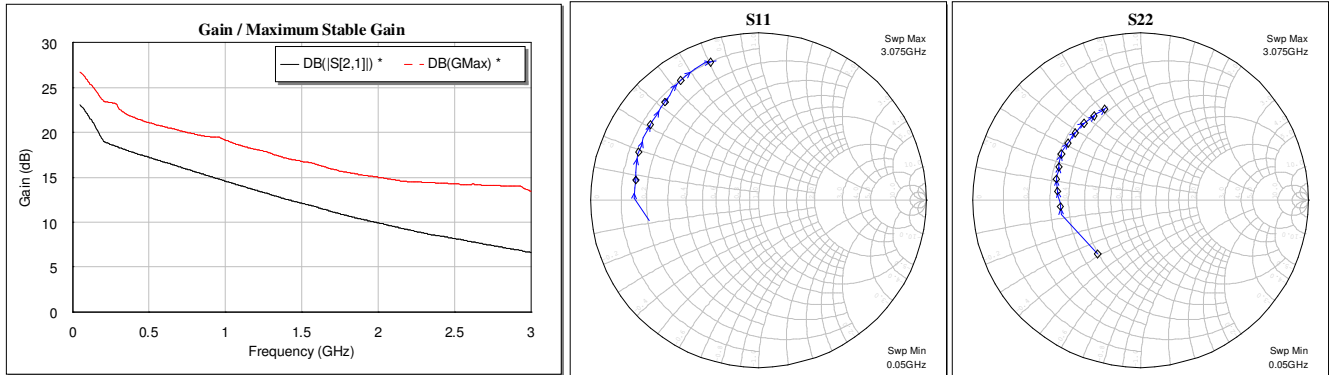

Notes:

The gain for the unmatched device in 50 ohm system is shown as the trace in black color. For a tuned circuit for a particular frequency, it is expected that actual gain will be higher, up to the maximum stable gain. The maximum stable gain is shown in the dashed red line. The impedance plots are shown from 50 – 3000 MHz, with markers placed at 0.5 – 3.0 GHz in 0.5 GHz increments.

S-Parameters (Vcc = +5 V, Icc = 150 mA, T = 25°C, unmatched 50 ohm system, calibrated to device leads)

Freq (MHz)	S11 (dB)	S11 (ang)	S21 (dB)	S21 (ang)	S12 (dB)	S12 (ang)	S22 (dB)	S22 (ang)
50	-3.61	-169.14	23.08	149.67	-30.46	17.14	-7.74	-128.38
100	-3.31	-173.35	21.93	148.90	-29.57	14.05	-7.80	-143.29
200	-2.62	179.12	19.02	146.43	-27.97	9.40	-6.40	-169.43
400	-2.62	173.23	17.74	136.11	-27.96	10.86	-6.33	-179.95
600	-2.54	168.30	16.69	123.77	-27.96	10.86	-6.09	173.78
800	-2.39	163.31	15.62	111.53	-27.96	10.62	-5.86	168.37
1000	-2.27	158.06	14.57	101.13	-26.02	9.88	-5.68	163.12
1200	-2.21	152.89	13.55	91.40	-26.02	8.87	-5.58	157.73
1400	-2.16	147.55	12.54	82.69	-26.02	7.57	-5.37	152.46
1600	-2.05	142.54	11.65	74.35	-26.02	5.95	-5.20	147.09
1800	-1.99	137.85	10.70	66.99	-25.08	4.22	-5.20	141.71
2000	-1.84	133.47	9.91	59.96	-24.44	2.37	-5.05	136.43
2200	-1.68	129.41	9.13	53.84	-24.44	0.24	-5.01	131.29
2400	-1.46	125.20	8.46	47.68	-24.44	-2.39	-4.89	126.16
2600	-1.33	120.48	7.85	41.30	-23.27	-5.53	-4.88	121.19
2800	-1.20	115.03	7.22	34.74	-23.10	-9.13	-4.73	116.28
3000	-1.17	109.05	6.62	27.78	-23.10	-12.86	-4.66	111.40

Device S-parameters are available for download off of the website at: <http://www.wj.com>

Application Circuit PC Board Layout

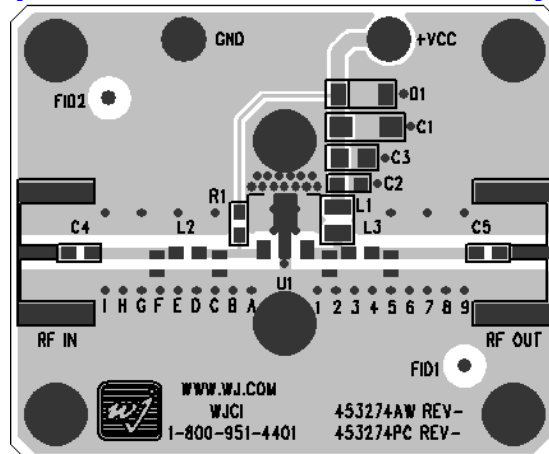

Circuit Board Material: .014" Getek, 4 layers (other layers added for rigidity), .062" total thickness, 1 oz copper

Microstrip line details: width = .026", spacing = .026"

The silk screen markers 'A', 'B', 'C', etc. and '1', '2', '3', etc. are used as placemarkers for the input and output tuning.

Specifications and information are subject to change without notice



900 MHz Application Circuit (AH114-89PCB900)

Typical RF Performance

Frequency	900 MHz
S21 – Gain	19 dB
S11 – Input Return Loss	-14 dB
S22 – Output Return Loss	-10 dB
Output IP3 (+11 dBm / tone, 1 MHz spacing)	+40 dBm
Output P1dB	+24 dBm
Noise Figure	5.0 dB
Supply Voltage	+5 V
Supply Current	150 mA

Measured parameters were taken at 25 °C.

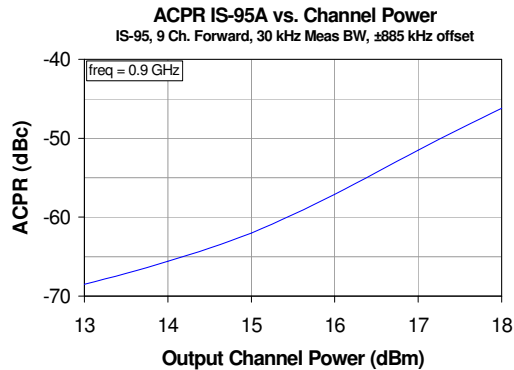
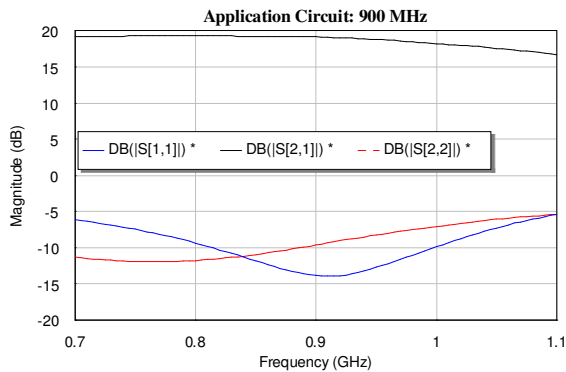
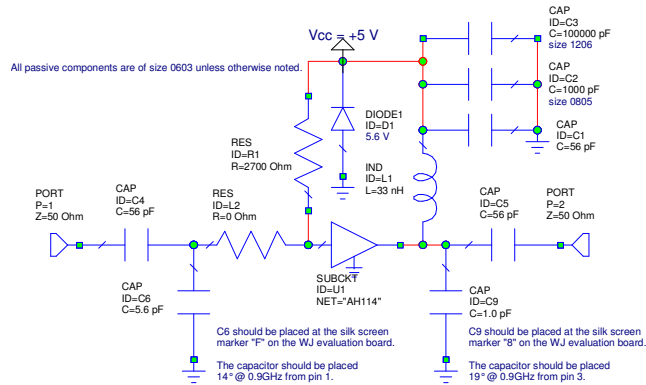

1900 MHz Application Circuit (AH114-89PCB1900)

Typical RF Performance

Frequency	1900 MHz
S21 – Gain	14.5 dB
S11 – Input Return Loss	-10 dB
S22 – Output Return Loss	-14 dB
Output IP3 (+11 dBm / tone, 1 MHz spacing)	+41 dBm
Output P1dB	+23 dBm
Noise Figure	5.0 dB
Supply Voltage	+5 V
Supply Current	150 mA

Measured parameters were taken at 25 °C.

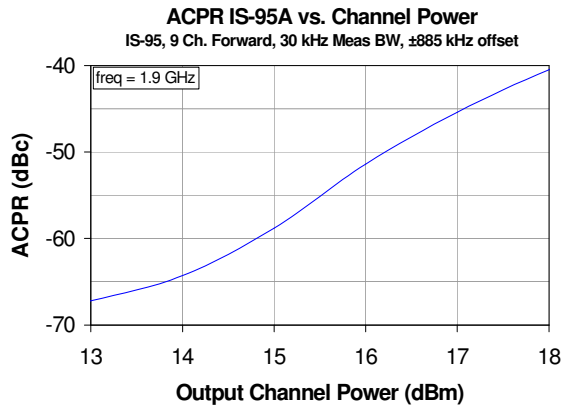
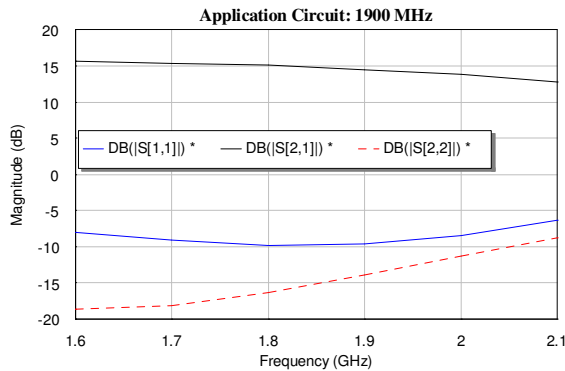
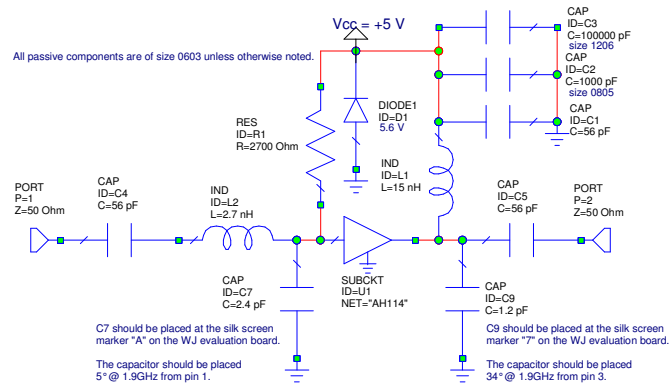

Specifications and information are subject to change without notice



2140 MHz Application Circuit (AH114-89PCB2140)

Typical RF Performance

Frequency	2140 MHz
S21 – Gain	14 dB
S11 – Input Return Loss	-25 dB
S22 – Output Return Loss	-20 dB
Output IP3 (+11 dBm / tone, 1 MHz spacing)	+23 dBm
Output P1dB	+40 dBm
Noise Figure	6.0 dB
Supply Voltage	+5 V
Supply Current	150 mA

Measured parameters were taken at 25 °C.

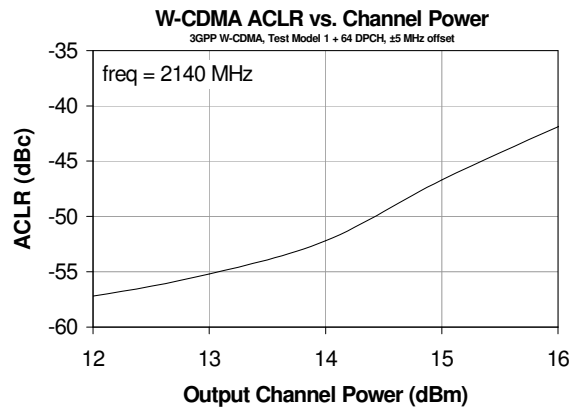
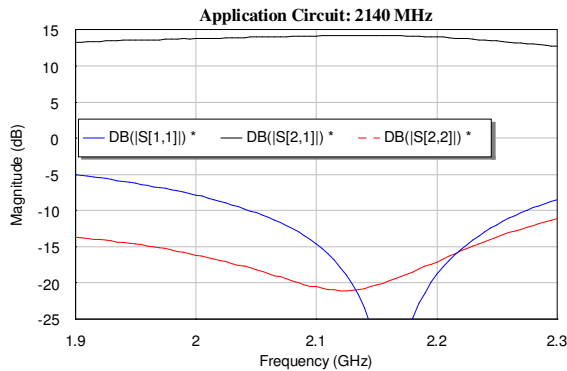
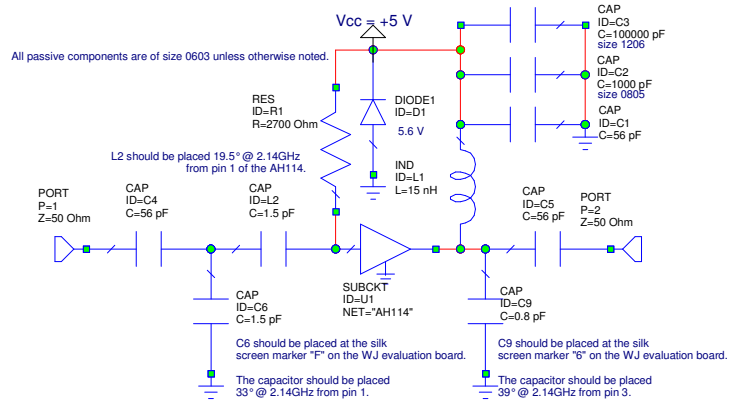

70 MHz Reference Design

Typical RF Performance

Frequency	70 MHz
S21 – Gain	23.4 dB
S11 – Input Return Loss	-15 dB
S22 – Output Return Loss	-14 dB
Output IP3 (+11 dBm / tone, 1 MHz spacing)	+44.5 dBm
Output P1dB	+23.8 dBm
Noise Figure	6.5 dB
Supply Voltage	+5 V
Supply Current	150 mA

Measured parameters were taken at 25 °C.

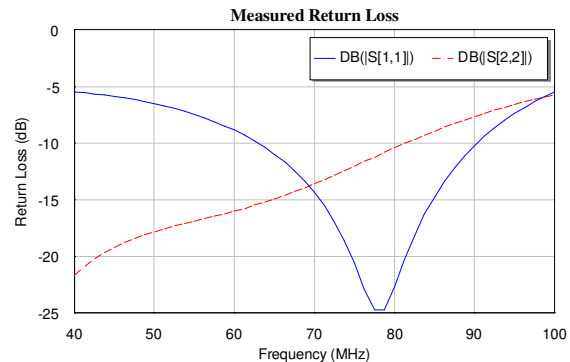
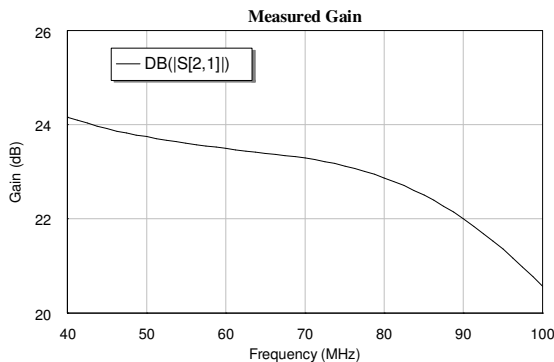
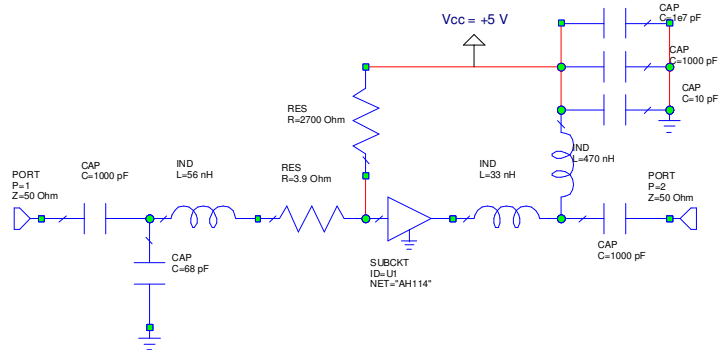

Specifications and information are subject to change without notice



110 MHz Reference Design

Typical RF Performance

Frequency	110 MHz
S21 – Gain	21.9 dB
S11 – Input Return Loss	-16 dB
S22 – Output Return Loss	-12 dB
Output IP3 (+11 dBm / tone, 1 MHz spacing)	+44 dBm
Output P1dB	+23.8 dBm
Noise Figure	6.6 dB
Supply Voltage	+5 V
Supply Current	150 mA

Measured parameters were taken at 25 °C.

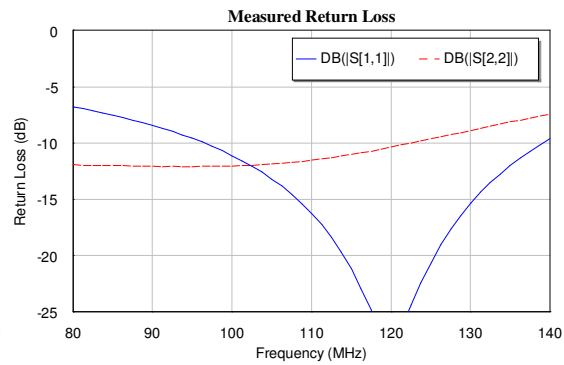
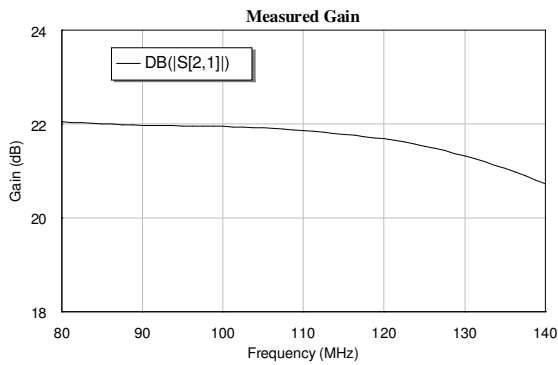
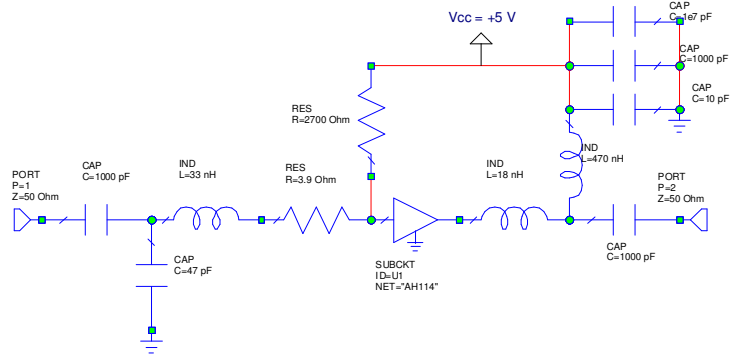



AH114 / ECG009

1/4 Watt, High Linearity InGaP HBT Amplifier

The Communications Edge™

Product Information

AH114-89 (SOT-89 Package) Mechanical Information

This package may contain lead-bearing materials. The plating material on the leads is SnPb.

Outline Drawing

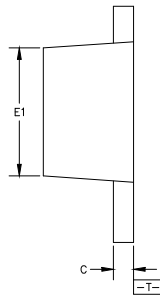
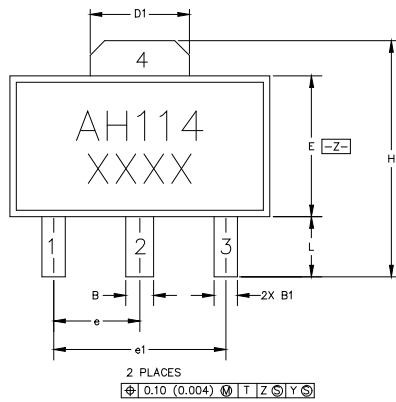

SYMBOL	MIN	MAX
A	1.40 (.055)	1.60 (.063)
B	.44 (.017)	.56 (.022)
B1	.36 (.014)	.48 (.019)
c	.35 (.014)	.44 (.017)
D	4.40 (.175)	4.60 (.181)
D1	1.62 (.064)	1.83 (.072)
E	2.29 (.079)	2.60 (.102)
E1	2.13 (.084)	2.29 (.090)
e	1.50 BSC (.059)	
e1	3.00 BSC (.118)	
H	3.94 (.155)	4.25 (.167)
L	.89 (.035)	1.20 (.047)
M	4.04 (.159)	4.19 (.165)

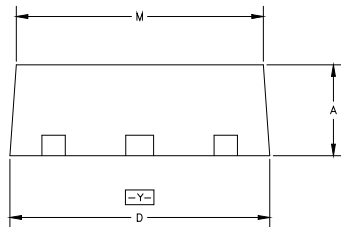

NOTES:

1. DIMENSIONS CONFORM WITH JEDEC TO-243C EXCEPT WHERE INDICATED.
2. DIMENSIONS ARE EXPRESSED IN MILLIMETERS(INCHES).
3. DIMENSIONING AND TOLERANCING IAW ANSI Y14.5M

Land Pattern

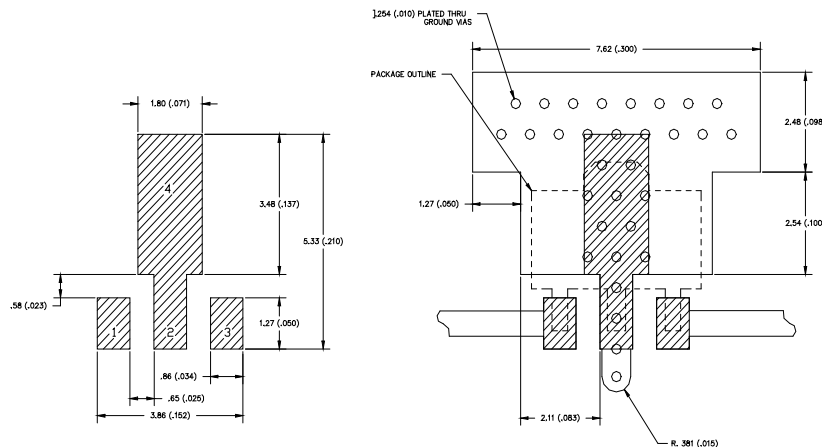

Thermal Specifications

Parameter	Rating
Operating Case Temperature	-40 to +85° C
Thermal Resistance, Rth ⁽¹⁾	149° C / W
Junction Temperature, Tjc ⁽²⁾	197° C

Notes:

1. The thermal resistance is referenced from the junction-to-case at a case temperature of 85° C.
2. This corresponds to the typical biasing condition of +5V, 150 mA at an 85° C case temperature. A minimum MTTF of 1 million hours is achieved for junction temperatures below 247° C.

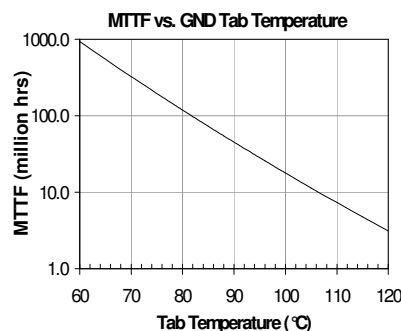

Product Marking

The component will be marked with an "AH114" designator with an alphanumeric lot code on the top surface of the package.

Tape and reel specification for this part is located on the website in the "Application Notes" section.

ESD / MSL Information



Caution! ESD sensitive device.

ESD Rating: Class 1A
 Test: Human Body Model (HBM)
 Standard: JEDEC Standard JESD22-A114

MSL Rating: Level 3 at +235° C convection reflow
 Standard: JEDEC Standard J-STD-020

Mounting Config. Notes

1. Ground / thermal vias are critical for the proper performance of this device. Vias should use a .35mm (#80 / .0135") diameter drill and have a final plated thru diameter of .25 mm (.010").
2. Add as much copper as possible to inner and outer layers near the part to ensure optimal thermal performance.
3. Mounting screws can be added near the part to fasten the board to a heatsink. Ensure that the ground / thermal via region contacts the heatsink.
4. Do not put solder mask on the backside of the PC board in the region where the board contacts the heatsink.
5. RF trace width depends upon the PC board material and construction.
6. Use 1 oz. Copper minimum.
7. All dimensions are in millimeters (inches). Angles are in degrees.

Specifications and information are subject to change without notice



AH114 / ECG009

1/4 Watt, High Linearity InGaP HBT Amplifier

The Communications Edge™

Product Information

AH114-89G (Green / Lead-free SOT-89 Package) Mechanical Information

This package is lead-free/Green/RoHS-compliant. It is compatible with both lead-free (maximum 260°C reflow temperature) and leaded (maximum 245°C reflow temperature) soldering processes. The plating material on the leads is NiPdAu.

Outline Drawing

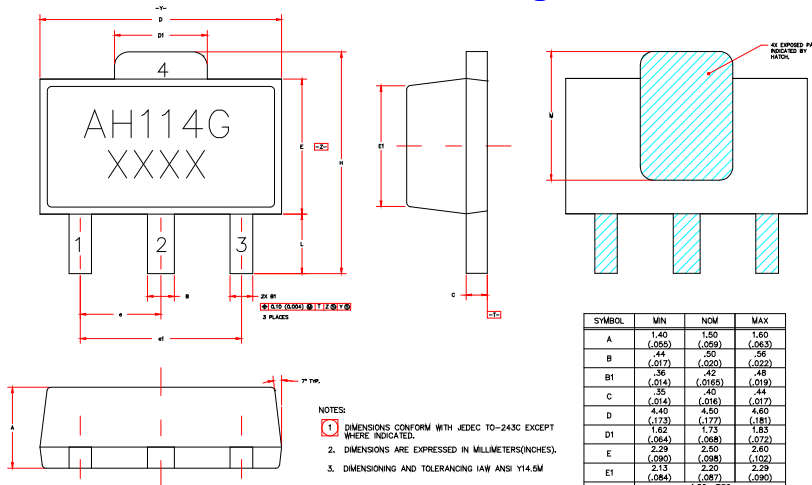

- NOTES:
 1. DIMENSIONS CONFORM WITH JEDEC TO-243C EXCEPT WHERE INDICATED.
 2. DIMENSIONS ARE EXPRESSED IN MILLIMETERS(INCHES).
 3. DIMENSIONING AND TOLERANCING IAW ANSI Y14.5M

Product Marking

The component will be marked with an "AH114G" designator with an alphanumeric lot code on the top surface of the package.

Tape and reel specification for this part is located on the website in the "Application Notes" section.

ESD / MSL Information



Caution! ESD sensitive device.

ESD Rating: Class 1A
 Test: Human Body Model (HBM)
 Standard: JEDEC Standard JESD22-A114

MSL Rating: Level 3 at +260° C convection reflow
 Standard: JEDEC Standard J-STD-020

Mounting Config. Notes

- Ground / thermal vias are critical for the proper performance of this device. Vias should use a .35mm (#80 / .0135") diameter drill and have a final plated thru diameter of .25mm (.010").
- Add as much copper as possible to inner and outer layers near the part to ensure optimal thermal performance.
- Mounting screws can be added near the part to fasten the board to a heatsink. Ensure that the ground / thermal via region contacts the heatsink.
- Do not put solder mask on the backside of the PC board in the region where the board contacts the heatsink.
- RF trace width depends upon the PC board material and construction.
- Use 1 oz. Copper minimum.
- All dimensions are in millimeters (inches). Angles are in degrees.

Land Pattern

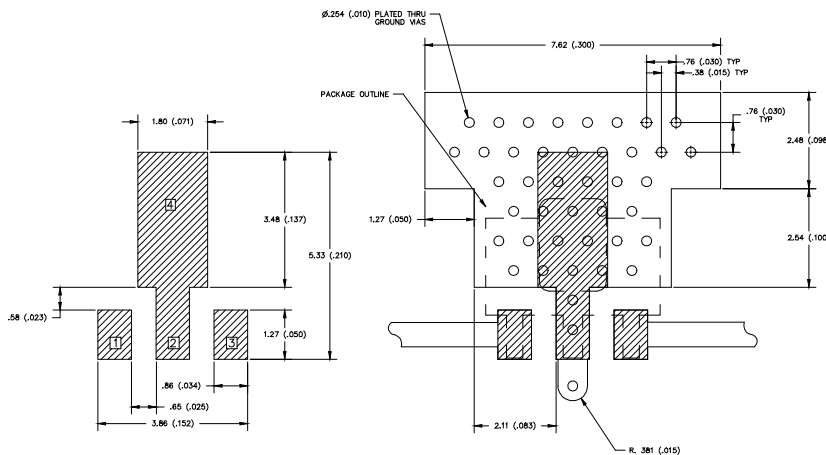

Thermal Specifications

Parameter	Rating
Operating Case Temperature	-40 to +85° C
Thermal Resistance, Rth ⁽¹⁾	149° C / W
Junction Temperature, Tjc ⁽²⁾	197° C

Notes:

- The thermal resistance is referenced from the junction-to-case at a case temperature of 85° C.
- This corresponds to the typical biasing condition of +5V, 150 mA at an 85° C case temperature. A minimum MTTF of 1 million hours is achieved for junction temperatures below 247° C.

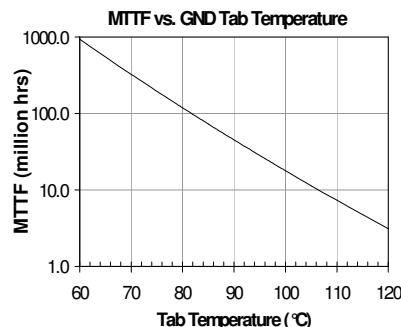

Specifications and information are subject to change without notice



AH114 / ECG009

1/4 Watt, High Linearity InGaP HBT Amplifier

The Communications Edge™

Product Information

ECG009B (SOT-89 Package) Mechanical Information

This package may contain lead-bearing materials. The plating material on the leads is SnPb.

Outline Drawing

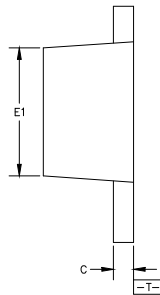
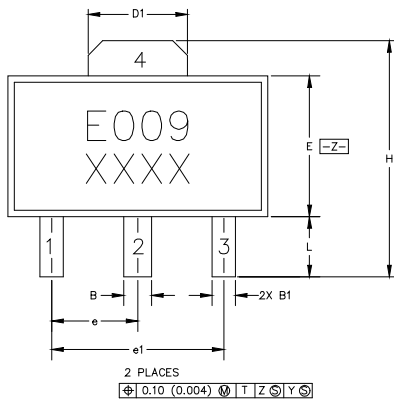

SYMBOL	MIN	MAX
A	1.40 (.055)	1.60 (.063)
B	.44 (.017)	.56 (.022)
B1	.36 (.014)	.48 (.019)
c	.35 (.014)	.44 (.017)
D	4.40 (.175)	4.60 (.181)
D1	1.62 (.064)	1.83 (.072)
E	2.29 (.079)	2.60 (.102)
E1	2.13 (.084)	2.29 (.090)
e	1.50 BSC (.059)	
e1	3.00 BSC (.118)	
H	3.94 (.155)	4.25 (.167)
L	.89 (.035)	1.20 (.047)
M	4.04 (.159)	4.19 (.165)

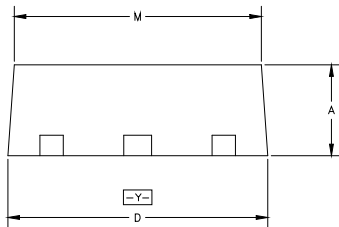

NOTES:

1. DIMENSIONS CONFORM WITH JEDEC TO-243C EXCEPT WHERE INDICATED.
2. DIMENSIONS ARE EXPRESSED IN MILLIMETERS(INCHES).
3. DIMENSIONING AND TOLERANCING IAW ANSI Y14.5M

Land Pattern

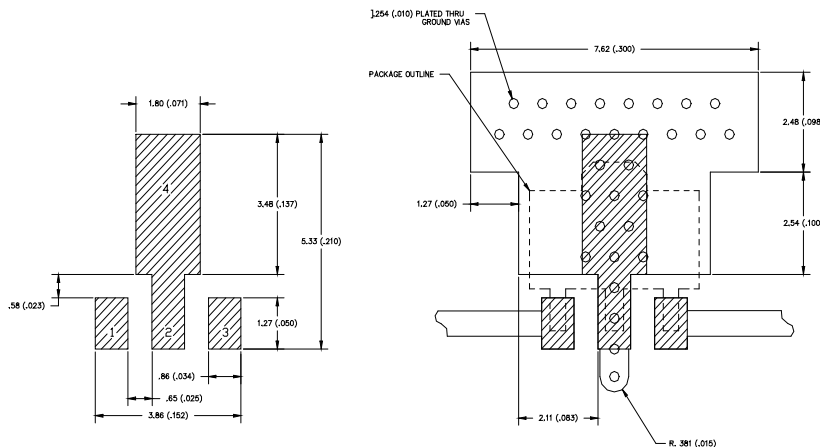

Product Marking

The component will be marked with an "E009" designator with an alphanumeric lot code on the top surface of the package.

Tape and reel specification for this part is located on the website in the "Application Notes" section.

ESD / MSL Information



Caution! ESD sensitive device.

ESD Rating: Class 1A
 Test: Human Body Model (HBM)
 Standard: JEDEC Standard JESD22-A114

MSL Rating: Level 3 at +235° C convection reflow
 Standard: JEDEC Standard J-STD-020

Mounting Config. Notes

1. Ground / thermal vias are critical for the proper performance of this device. Vias should use a .35mm (#80 / .0135") diameter drill and have a final plated thru diameter of .25 mm (.010").
2. Add as much copper as possible to inner and outer layers near the part to ensure optimal thermal performance.
3. Mounting screws can be added near the part to fasten the board to a heatsink. Ensure that the ground / thermal via region contacts the heatsink.
4. Do not put solder mask on the backside of the PC board in the region where the board contacts the heatsink.
5. RF trace width depends upon the PC board material and construction.
6. Use 1 oz. Copper minimum.
7. All dimensions are in millimeters (inches). Angles are in degrees.

Thermal Specifications

Parameter	Rating
Operating Case Temperature	-40 to +85° C
Thermal Resistance, Rth ⁽¹⁾	149° C / W
Junction Temperature, Tjc ⁽²⁾	197° C

Notes:

1. The thermal resistance is referenced from the junction-to-case at a case temperature of 85° C.
2. This corresponds to the typical biasing condition of +5V, 150 mA at an 85° C case temperature. A minimum MTTF of 1 million hours is achieved for junction temperatures below 247° C.

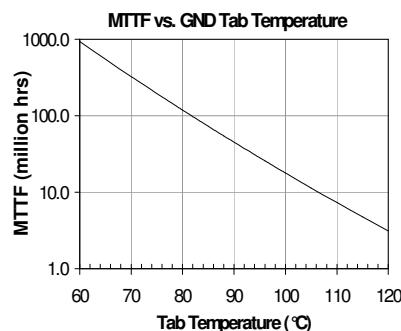

Specifications and information are subject to change without notice